

# Lock N' Ride Cab Doors

KIT PN 2879111



# POLARIS

The Way Out

## Application: Polaris RGM

**NOTE: THESE INSTRUCTIONS ARE FOR THE RGM 2-PASS VEHICLE ONLY. IF YOU HAVE THE 4-PASS RGM CREW VEHICLE, PLEASE REFER TO THE RGM CREW INSTRUCTION SHEET.**

Before you begin, read these instructions and check to be sure all parts and tools are accounted for. Please retain these installation instructions for future reference and parts ordering information.

**Installation Time:** Approximately 2 Hours

### Hardware Kit Components:

<u>Number</u>	<u>QTY.</u>	<u>Part Description</u>	<u>Number</u>	<u>QTY.</u>	<u>Part Description</u>
1	2	Inner Tube Clamp	14	2	1/8" Rubber Cushion
2	4	Strap Clamp	15	2	1/16" Rubber Cushion
3	2	Striker Pin	N/A	2ft	1/2" Trim
4	4	Hinge Plate	N/A	8	M6 Nylock Nut
5	2	Passenger Female Hinge	N/A	8	1/4" Flat Washer
6	2	Driver Female Hinge	N/A	8	M6 x 25mm Screw
7	1	Driver Latch Pin Bracket	N/A	8	M8 x 30mm Screw
8	1	Passenger Latch Pin Bracket	N/A	8	M8 Fender Washer
9	2	Striker Mount Bracket	N/A	2	M8 Nylock Nut
10	1	Driver Striker Mount Bracket	N/A	2	M10 Nylock Nut
11	1	Passenger Striker Mount Bracket	N/A	2	M8 x 65mm Bolt
12	1	Driver Closeout Bracket	N/A	2	Torx Screw
13	1	Passenger Closeout Bracket	N/A	2	M10 Flat Washer
			N/A	2	M8 x 25mm Screw

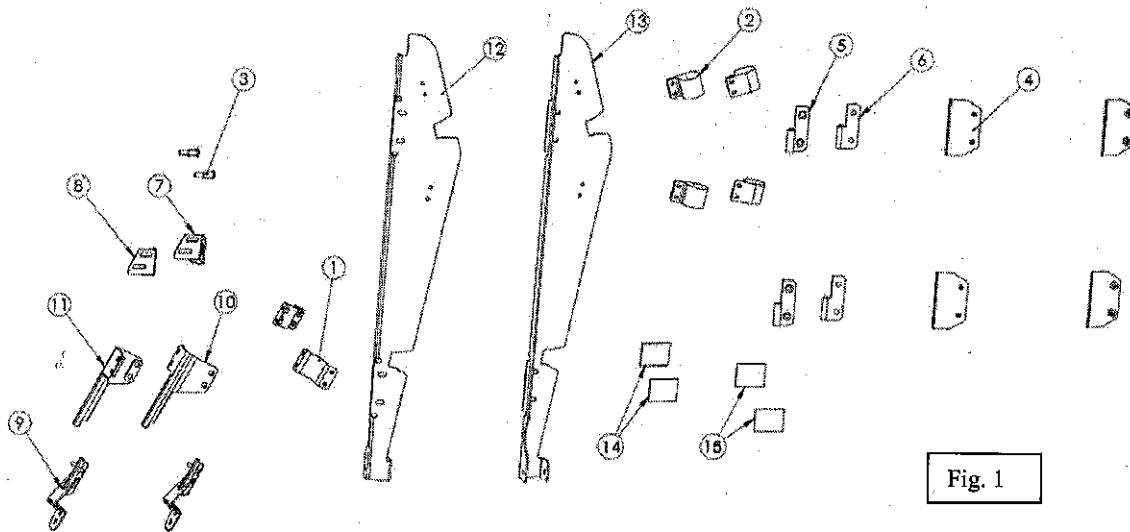

### Installation Supplies:

- M5 Allen Wrench
- 5/16" Allen
- 10mm Wrench
- 13mm Wrench

**IMPORTANT:** Your Polaris accessory kit is exclusively designed for your Polaris vehicle. Please read the installation instructions and operator's manual thoroughly before beginning. Installation of any item is easier if the vehicle is clean and free of debris.

## INSTALLATION INSTRUCTIONS

**NOTE:** Remove windshield if previously installed. For best results, install these parts in the order listed below:

**Quick tip for the installer:**

- All fasteners are loosely installed from the factory. It is the install technician's responsibility to tighten all fasteners during the final adjustment process.
- There is 2 feet of 1/2" adhesive trim included in this kit. This is provided for the install technician to use at their discretion where needed.

**A. Install Driver Closeout Bracket:**

1. Refer to Fig. 2. Remove the stock bolt from the bottom of the B-Pillar.
2. Align the bottom mount hole in the driver closeout bracket with the mount hole from Step 1. Fasten using a M8 x 65mm bolt and M8 nylock nut.
3. Place (2) strap clamps into position on the frame bar as shown in Fig. 3. Fasten the strap clamps to the driver closeout bracket using (4) M6 x 25mm screws, (4) 1/4" flat washers, and (4) M6 nylock nuts.
4. Refer to Fig. 4. Align a hinge plate and driver female hinge with the driver closeout bracket. Fasten using (2) M8 x 25mm screws.
5. Repeat Step 4 for lower hinge location.
6. After door is installed, fasten a torx screw at location shown in Fig. 4 to attach the door tether on the door to the driver closeout panel.

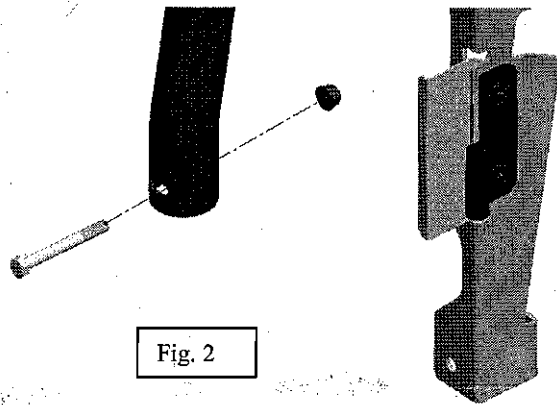

Fig. 2

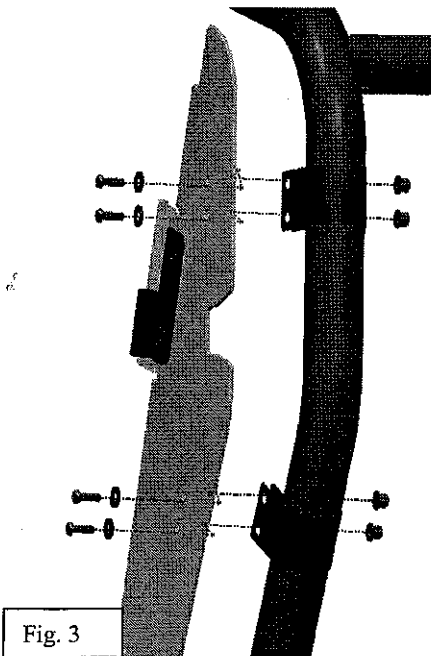

Fig. 3

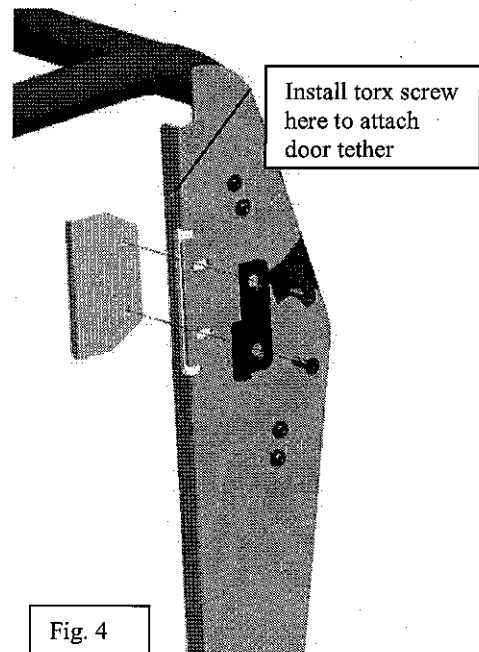

Fig. 4



### B. Install Striker Mount

1. Refer to Fig. 5. Remove the two bolts in the driver side front tube frame using a 5/16" allen wrench. Place the strike mount bracket in place, and re-fasten. Torque fasteners to 25 ft/lbs.
2. Align the driver striker mount bracket with the striker mount bracket as shown in Fig. 6. Apply 1/8" rubber cushion in between the driver striker mount bracket and the frame bar.
3. Align the inner tube clamp with the driver striker mount bracket as shown in Fig. 7. Apply 1/16" rubber cushion in between the inner tube clamp and the frame bar.
4. Refer to Fig. 8. Use (4) M8 x 30mm screws and (4) M8 washers to fasten the driver latch pin bracket, driver striker mount bracket, and inner tube clamp.
5. Install the striker pin, M10 flat washer and M10 nylock nut as shown in Fig. 8.

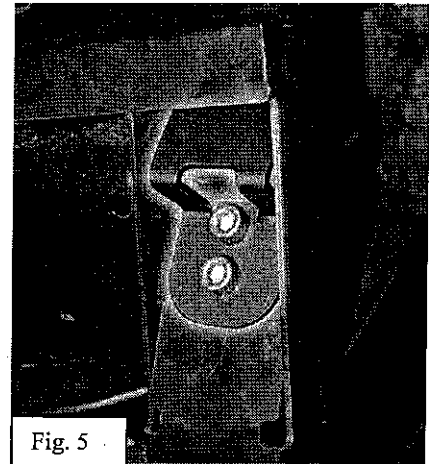

Fig. 5

### C. Install Doors and Final Adjustment

1. Install the driver door onto the hinges installed in Step A.
2. Once general up/down alignment is reached, tighten all hinges on the door and driver closeout bracket.
3. Adjust the driver latch pin bracket and striker pin from Step B until the door latches smoothly.
4. Once proper door latching is consistently achieved, tighten all hardware from Step B.

### D. Repeat Steps A-C for Passenger Door

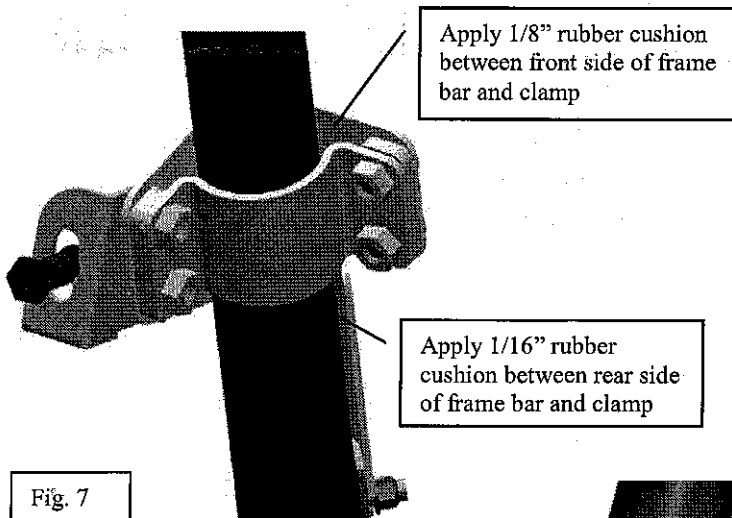

Fig. 7

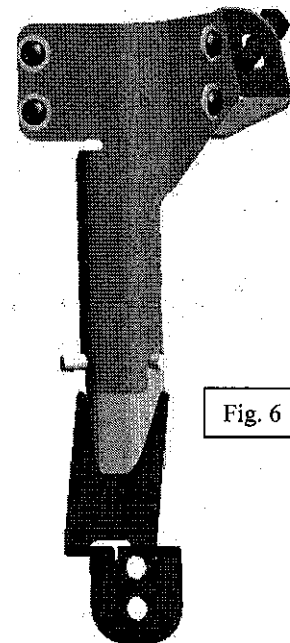

Fig. 6

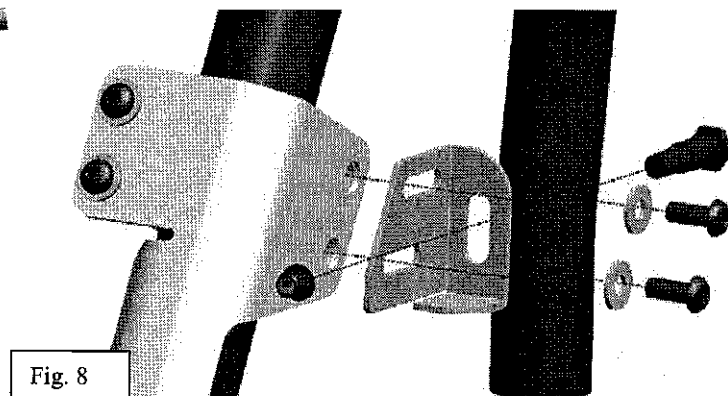

Fig. 8